



## ICE-Trade sro

International Conveyor Equipment & Trading

Pila - Razcestie 9A  
SK - 900 89 Casta, Slovakia

Tel. + 421 948 222 891

[info@ice-trade.com](mailto:info@ice-trade.com)

[www.ice-trade.com](http://www.ice-trade.com)

## ICE-Trade Flexi Rollers

### Flexi Roll Rubber Garland Rollers



### Dimensions Rubber Garland Rollers

Belt mm.	A	B	C	G	S	N° of Discs	Hook Type	Weight kg
400/16"	696	669	484	76	57	7	1	3.5
500/20"	797	772	584	76	57	9	1	4.0
600/24"	902	878	680	76	57	10	1	4.2
650/26"	952	928	738	76	57	11	1	4.5
700/28"	1.003	980	790	76	57	11	1	4.6
750/30"	1.055	1.032	840	76	57	12	1	4.7
800/32"	1.105	1.082	892	76	57	13	1	5.0
900/36"	1.205	1.182	992	76	57	15	1	5.6
1.000/42"	1.404	1.370	1.140	92	62	17	2	9.5
1.200/48"	1.554	1.520	1.298	92	62	19	2	10.3
1.400/54"	1.713	1.679	1.454	92	62	21	2	11.0

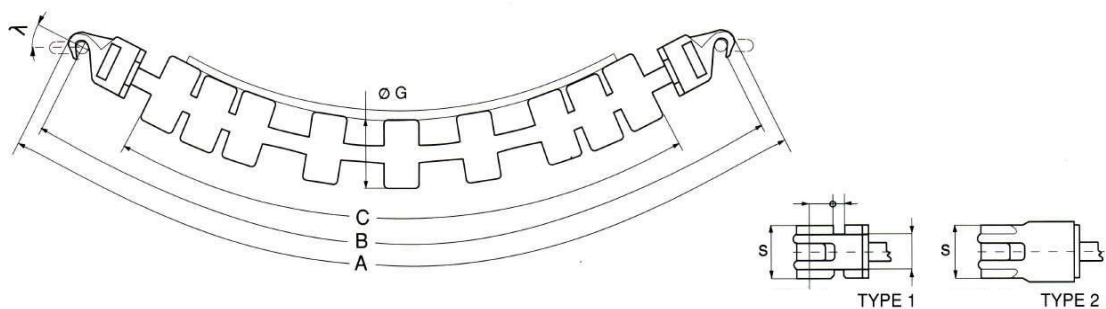

### Hook types for the Rubber Garland Rollers

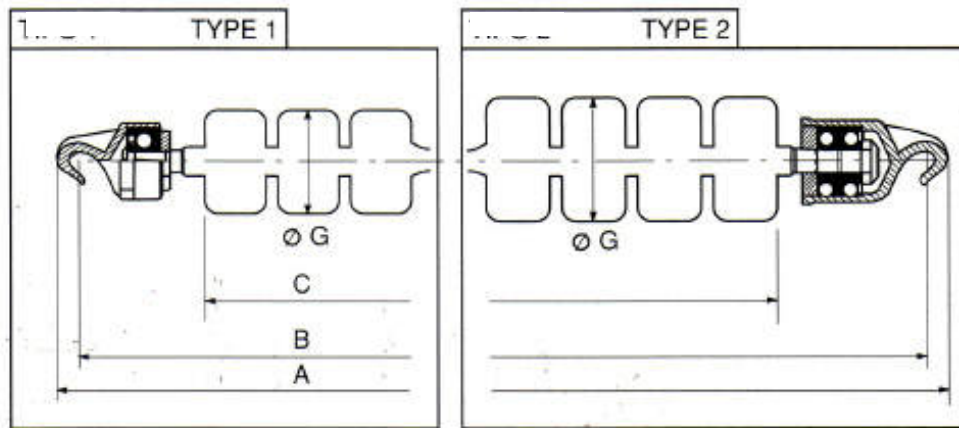

### Supports for the Rubber Garland Rollers

#### Dimensions supports

Belt width	A	B	C	D	G	H	I	J	Trough angle
400	707	640	248	263	200	140	50	12	20°
500	804	738	246	261	200	140	50	12	
600	896	830	248	263	200	140	50	12	
650	954	888	248	263	200	140	50	12	
750	1.034	968	248	263	200	140	50	12	
800	1.106	1.040	250	265	200	140	50	12	
900	1.184	1.118	282	297	200	140	50	12	
1.000	1.390	1.324	310	327	250	190	80	14	
1.200	1.543	1.477	353	371	250	190	80	14	
1.400	1.697	1.631	376	394	250	190	80	14	
400	688	621	268	283	200	140	50	12	25°
500	788	723	268	283	200	140	50	12	
600	880	814	272	287	200	140	50	12	
650	943	875	268	283	200	140	50	12	
750	1.017	951	273	288	200	140	50	12	
800	1.095	1.027	268	283	200	140	50	12	
900	1.166	1.100	305	320	200	140	50	12	
1.000	1.368	1.300	343	361	250	190	80	14	
1.200	1.521	1.453	387	407	250	190	80	14	
1.400	1.672	1.605	415	434	250	190	80	14	
500	774	708	298	299	200	140	50	12	30°
600	852	786	313	313	200	140	50	12	
650	921	855	293	308	200	140	50	12	
750	1.004	938	293	308	200	140	50	12	
800	1.068	1.002	301	316	200	140	50	12	
900	1.136	1.070	334	349	200	140	50	12	
1.000	1.343	1.000	375	393	250	190	80	14	
1.200	1.493	1.427	426	444	250	190	80	14	
1.400	1.642	1.575	456	474	250	190	80	14	

**Dimensions supports**

Belt width	A	B	C	D	G	H	I	J	Trough angle
500	754	688	302	319	200	140	50	12	35°
600	825	759	325	340	200	140	50	12	
650	900	833	316	330	200	140	50	12	
750	980	914	314	329	200	140	50	12	
800	1.044	978	326	340	200	140	50	12	
900	1.119	1.053	349	364	200	140	50	12	
1.000	1.310	1.246	407	425	250	190	80	14	
1.200	1.460	1.390	460	479	250	190	80	14	
1.400	1.607	1.540	493	510	250	190	80	14	
650	875	808	336	352	200	140	50	12	40°
750	944	878	348	363	200	140	50	12	
800	1.014	950	350	366	200	140	50	12	
900	1.084	1.018	383	398	200	140	50	12	
1.000	1.277	1.210	438	457	250	190	80	14	
1.200	1.421	1.354	494	511	250	190	80	14	
1.400	1.567	1.500	530	549	250	190	80	14	
800	985	920	375	391	200	140	50	12	45°
900	1.033	967	416	431	200	140	50	12	
1.000	1.283	1.170	469	486	250	190	80	14	
1.200	1.380	1.315	527	545	250	190	80	14	
1.400	1.521	1.455	565	584	250	190	80	14	

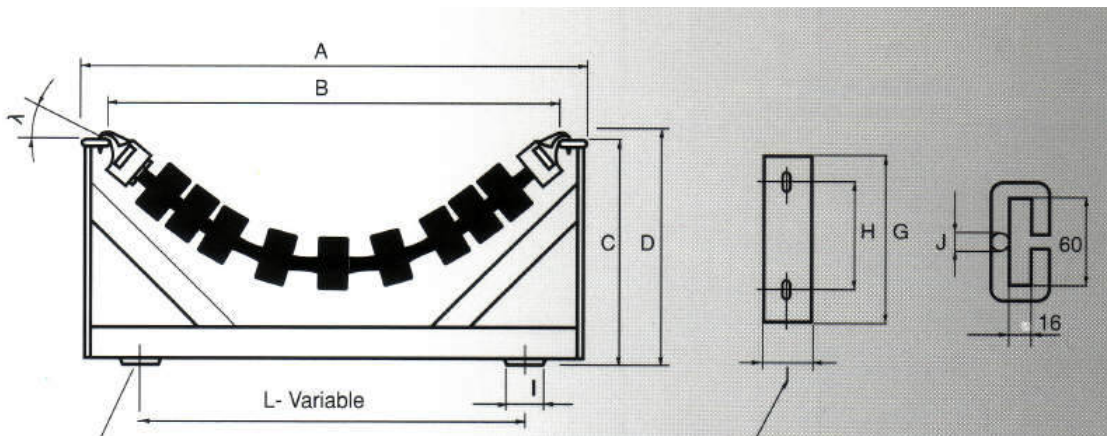

**Flexi Roller with support**





## ICE-Trade sro

International Conveyor Equipment & Trading

Tel. + 421 948 222 891

[info@ice-trade.com](mailto:info@ice-trade.com)

[www.ice-trade.com](http://www.ice-trade.com)

The basis of the rubber garland roller is a steel cable, with a breaking strength of 6.600 kg. The cable, also available in stainless steel, is vulcanized together with the individual steel discs and forms together with the lining and wheels one single assembly. Therefore, the wheels cannot move on the cable and the complete garland set is protected against external influences by high quality rubber. Applications: environments with high humidity, chemicals, dust.

### Flexi Roll Return idlers

### Flexi Roll Rigid Return Idlers

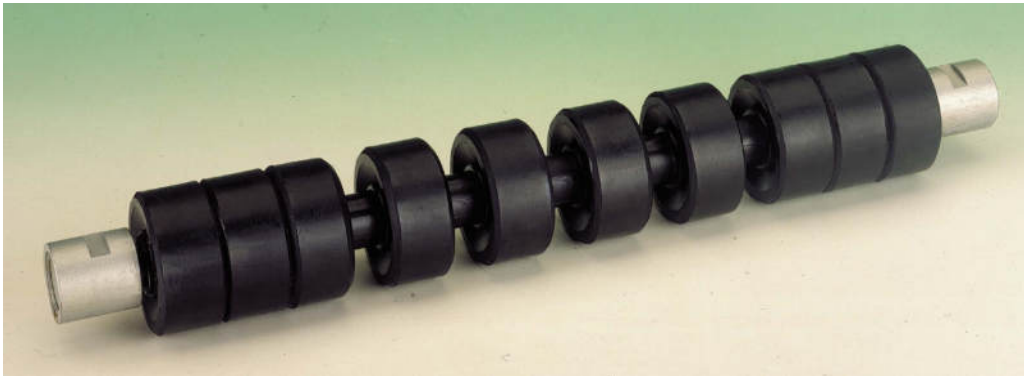

### Dimensions Rigid Return Idlers

Belt	A	B	C	D	ØE	F	G	H	N° Discs
400/15"	559	539	515	441	76	12	40	57	6
500/20"	659	639	615	531	76	12	40	57	8
600/24"	759	739	715	631	76	12	40	57	9
650/26"	808	788	764	681	76	12	40	57	9
800/32"	959	939	915	835	76	12	40	57	10
900/32"	1059	1039	1015	935	76	12	40	57	12
1000/42"	1265	1250	1220	1030	90	14	50	65	13
1200/48"	1465	1450	1420	1230	90	14	50	65	14

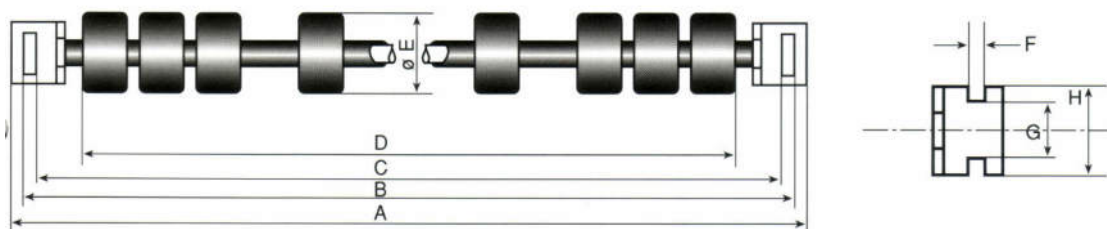

### Supports for the Rigid Return Idlers

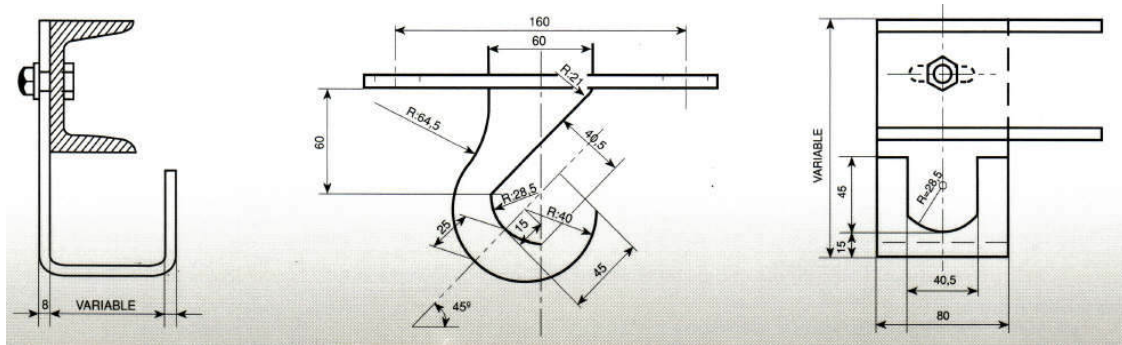

### Flexi Roll Self Cleaning Return Idlers



### Dimensions Self Cleaning Return Idlers

**Roller ø 89 mm.**

Belt m/m.	A	B	C	D	E	F	G	N° Discs	Weight kg.
500	575	640	89	14	20	63	92	6	6,4
600	675	740	89	14	20	63	92	7	7,5
650	725	790	89	14	20	63	92	8	8,0
800	875	940	89	14	20	63	92	10	10,0
1000	1115	1180	89	18	25	63	92	12	12,3
1200	1315	1380	89	18	25	63	92	14	14,3
1400	1515	1580	89	18	25	63	92	16	16,4
1600	1715	1780	89	18	25	63	92	18	18,6
1800	1915	1980	89	18	25	63	92	21	22,0
2000	2115	2180	89	18	25	63	92	23	24,4

## Dimensions Self Cleaning Return Idlers

### Roller $\varnothing$ 133 mm.

Belt m/m.	A	B	C	D	E	F	G	N° Discs	Weight kg.
500	575	640	133	14	20	89	142	4	11,2
600	675	740	133	14	20	89	142	4	12,1
650	725	790	133	14	20	89	142	5	13,8
800	875	940	133	14	20	89	142	6	16,5
1000	1115	1180	133	18	25	89	142	7	20,2
1200	1315	1380	133	18	25	89	142	9	24,6
1400	1515	1580	133	18	25	89	142	10	27,7
1600	1715	1780	133	18	25	89	142	12	32,3
1800	1915	1980	133	18	25	89	142	13	35,6
2000	2115	2180	133	18	25	89	142	15	40,1

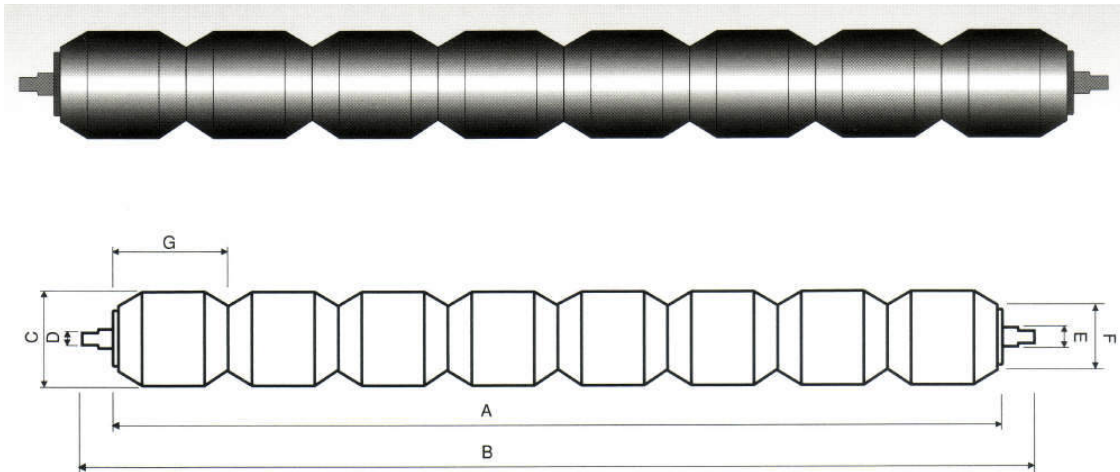

## Flexi Roll Rigid Return Idlers

Those are produced the same way as the Rubber Garland Rollers.

With the Rigid Return Idlers, a steel or stainless steel axle forms the basis.

## Flexi Roll Self Cleaning Return Idlers

Covered with a special rubber, the Self Cleaning Idlers are the ideal solution against abrasion, corrosion and material built up.

The can be adapted to any installation.

Advantages:

- hot vulcanized rubber, either in black or white FDA
- perfect adherence of the belt
- allow good alignment of the belt



## Flexi Roll Self-Centering Rollers



### Dimensions Self-Centering Rollers

For a single belt direction

Type SCR-S	Belt width	Shaft length		Tube length		Tube $\varnothing$	Shaft $\varnothing$
		A	B	C			
400	400	575	525	475	159	40	
500	500	675	625	575	159	40	
650	650	825	775	725	159	40	
800	800	975	925	875	159	40	
1000	1000	1215	1165	1115	159	40	
1200	1200	1415	1365	1315	159	40	
1400	1400	1615	1565	1515	159	40	

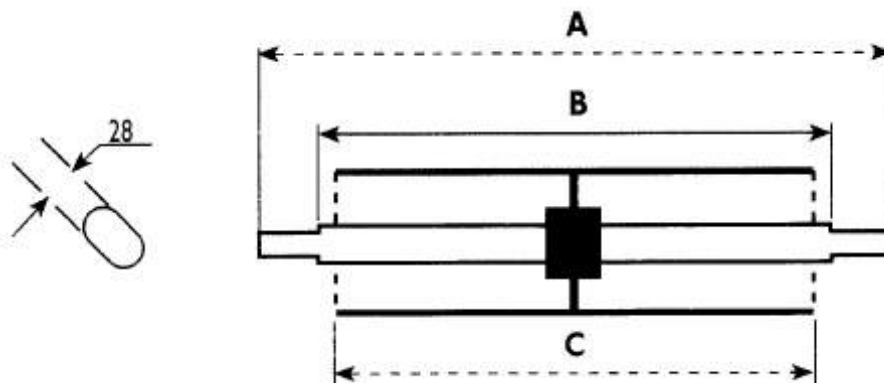

### Supports for the Self-Centering Rollers, SCR-S

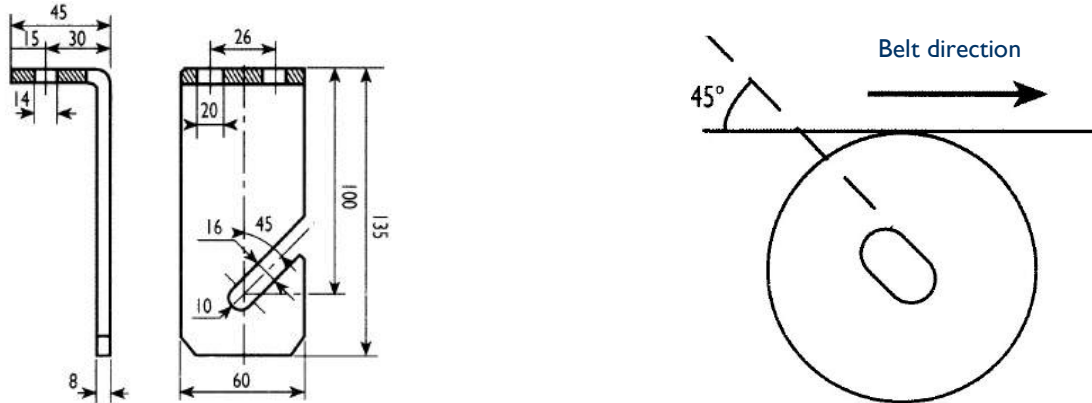

### Dimensions Self-Centering Rollers

#### For reversible belts

Type SCR-R	Belt width	A	Tube length B	Tube $\phi$	Shaft $\phi$
400	400	525	475	159	40
500	500	625	575	159	40
650	650	775	725	159	40
800	800	925	875	159	40
1000	1000	1165	1115	159	40
1200	1200	1365	1315	159	40
1400	1400	1565	1515	159	40

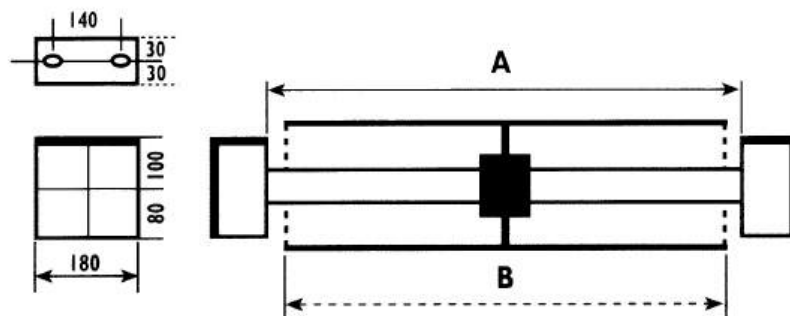

For installations shorter than 30 m. a single Self-Centering Roller will be sufficient.  
 For longer conveyors the pitch distance between the SCR's is approx. 25 m.  
 With reversible belts longer than 20 m., it is recommended to place a SCR-R unit with a pitch of min. 2 m. from the drive and tail pulley.  
 The SCR-s are covered with 45° Shore high quality rubber, hot vulcanized.

For further information, please contact us.